

# **Silverwood Architectural Review Guidelines**

Reviewed August 2023

The Silverwood Architectural Review Committee (SARC) has the authority to recommend further modifications and/or additions to plans based upon its aesthetic sensibility which may or may not be coherent with the guideline. The SARC reserves the right to propose amendments to these guidelines when necessary to maintain high quality, as new products evolve in the market, or when in its judgment, the Guideline itself needs revision for purely design or economic reasons and must be adopted by the Board of Directors.

## EXHIBIT "B" TO DECLARATION OF COVENANTS, CONDITIONS, EASEMENTS AND RESTRICTIONS FOR SILVERWOOD PLANTATION PROPERTY RIGHTS, EASEMENTS & USE RESTRICTIONS

**1. Easements of Use and Enjoyment of Common Areas.** Every Owner shall have a non-exclusive right and easement of use and enjoyment in and to the Common Areas which shall be appurtenant to and shall pass with the title to his Lot, subject to the following:

**(a) Right of the Association.** Upon a majority vote of its Board of Directors and the approval of Declarant, so long as Declarant shall be the Class B member of the Association, to dedicate or transfer title to all or any portion of the Common Areas for such purpose and subject to such conditions as the Board of Directors may determine. No such dedication or transfer of title, other than a dedication or transfer of any roads or utilities to any public agency, authority, or utility or to any private utility serving the Property or any portion thereof, shall be effective unless an instrument agreeing to such dedication or transfer has been approved by at least a majority of the votes which the Class A members of the Association present, or represented by proxy, are entitled to cast at a meeting duly called for such purpose; and

**(b) Right of the Association.** Upon a majority vote of its Board of Directors, and the approval of Declarant, so long as Declarant shall be the Class B member of the Association, to grant a license to use or easement over all or any portion of the Common Areas to any public entity, authority or utility, or to any other person or entity for such purpose and subject to such conditions as the Board of Directors may determine in its sole discretion; and

**(c) Rights of Use.** Such other covenants, conditions, easements, rights and restrictions may be set forth in this Declaration or the Rules and Regulations promulgated by the Board of Directors from time to time. Any Owner may delegate, in accordance with the Bylaws and subject to the Rules and Regulations of the Association, his right of use and enjoyment in and to the Common Areas and facilities located thereon to the members of his, family, his tenants and guests.

**2. Association's Rights and Easements.** In addition to any other rights and easements set forth in this Declaration, the Association, for the benefit of all Owners and Occupants, shall have the following rights and easements:

**(a) Access.** The utility, ditch, drainage, and other easements on, over, through, under and across the Property, as shown on the Plat, for access and for the construction, use and maintenance of utilities and a drainage system serving the Property, or any portion thereof; and

**(b) Easement.** A general easement on, over, through, under and across all portions of the Property for the purpose of performing utility services, exercising its rights or enforcing the provisions set forth in this Declaration or in any other document or agreement affecting the Property, or any portion thereof. In the exercise of the rights and easements set forth in this Paragraph 2, the Association, or its successor or assign, shall repair any damage to any portion of the Property Occasioned by such exercise and shall restore such damaged portion of the Property, as nearly as practicable, to its condition prior to such exercise.

**3. Utilities and Other Common Service Facilities.** Any provision of this Declaration to the contrary notwithstanding, Declarant, so long as Declarant shall be the Class B member of the Association, and thereafter the Association upon a majority vote of its Board of Directors, is hereby authorized and empowered to grant such permits, licenses and easements as Declarant or the Board of Directors, as the case may be, shall deem necessary and appropriate upon, across, above and under the Property, or any portion thereof, on which buildings or other improvements have not or are not intended to be constructed for the installation, repairing, replacing and maintaining of all utilities or other common service facilities serving the Property, any portion thereof or any adjoining property, including, but not limited to gas, water, sanitary sewer, telephone, electricity, storm drainage, master television antenna, cable television system or security system. It shall be expressly permissible for Declarant or the Association, as the case may be, to install, repair, replace and maintain or to authorize the installation, repairing, replacing and maintaining of such poles, pipes, wires, conduits, cables and other equipment related to the providing of any such utility or service. Should any party furnishing any such utility or service request a specific permit, license or easement by separate recordable document, Declarant, or the Association, as the case may be, shall have the right to execute and deliver such written document and every grantee of any interest in any property located within the Property consents thereto and further hereby agrees to give his specific written consent thereto in recordable form if requested by Declarant or the Board of Directors. Any permit, license or easement granted pursuant hereto by Declarant or the Association shall be and remain in full force and effect perpetually or for such shorter period of time as may be specified in the particular instrument creating the same. The foregoing notwithstanding, it shall be a condition of any permit, license or easement granted pursuant to this Paragraph 3, that the grantee (i) shall repair any damage to any portion of the Property occasioned by such grant, and (ii) shall not unnecessarily interfere with the use of such Property by the Owner thereof.

**4. Architectural Approval and Use Restrictions.** The following architectural, maintenance and use restrictions shall apply to each, and every Lot and Common Area now or hereafter subjected to this Declaration. All of the rights or functions reserved to Declarant in this Paragraph 4 shall be exercised by Declarant, so long as Declarant shall be the Class B member of the Association, and thereafter shall be exercised by the Association upon a majority vote of its Board of Directors; provided, however, Declarant shall have the unilateral right to transfer, convey or assign to the Association at any time and from time to time all or any of the rights or functions reserved to Declarant in this Paragraph 4 while remaining a Class B member of the Association.

**(a) Residential Use.** All Lots shall be used for residential purposes exclusively. Except as hereinafter provided, no structure or other improvements shall be erected, altered, placed, maintained or permitted to remain on any Lot other than one (1) detached single family dwelling having the minimum number of square feet of finished interior space and enclosed garage, as set forth with respect to such Lot on. Schedule 1 attached hereto, and such other small one—story accessory buildings as may be approved by Declarant. No business or business activity shall be carried on without written approval of Declarant and in accordance with any and all zoning regulation<sup>5</sup> of Effingham County, Georgia affecting said Lot; provided, however, that nothing herein shall prevent Declarant from using any Lot owned by Declarant for the purpose of carrying on business related to the development and management of the Property. The foregoing notwithstanding, any Lot owned by the Association, may be used for any non—residential purpose benefitting all Owners, provided that such use shall be approved by the Owners of all Lots adjoining any boundary of such Lot at the time such use is first commenced.

*Exterior Lot or Dwelling Modifications, Renovations, Alterations, Changes, and Improvements*

*The “Silverwood Architectural Review Committee Approval Request” form will be used to obtain prior written approval of any and all exterior Lot or dwelling modifications, renovations, alterations, changes, and improvements. Any variances to the below required particulars must be approved on an individual basis by the Board of Directors. A formal SARC Approval Request form is to be initiated by the lot owner and must first be approved through the SARC. Upon the SARC’s written approval, the work can then be initiated. For variance approvals, the SARC must notify the Board of Directors in advance and attain concurrence prior to approving the variance approval.*

**(b) Subdivision of a Lot.** No Lot shall be subdivided, or its boundary lines changed, except with the prior written approval of Declarant. Declarant, however, hereby expressly reserves the right to replat any two (2) or more Lots in order to create a modified Lot or Lots, and ‘to take such other steps as reasonably may be necessary to make such replated Lot or Lots suitable as a building site or sites. All of the covenants and restrictions set forth herein shall apply to each such Lot, if any, so created. Any such division, boundary line change or replated Lot(s) shall comply with the applicable Effingham County zoning regulations.

**(c) Approval of Plans.** No building, fence, wall, road, driveway, parking area, tennis court, swimming pool, utility line or system, or other structure or improvement of any kind shall be erected, placed, altered, added to, modified, maintained or reconstructed in any way on any Lot until the plans therefore, and for the proposed location thereof upon the Lot, shall have been approved in writing by Declarant. “Improvement” shall mean and include any improvement, change or modification of a Lot, other than the interior of any building, from the state existing on the date of the conveyance of such Lot by Declarant to an Owner. Before taking any action requiring approval under this Paragraph, an Owner shall submit to Declarant a construction schedule and two (2) complete sets of final plans and outline specifications, showing site plan, including parking and utilities, landscape layout, floor plans, exterior elevations and exterior materials, colors and finishes.

*A pre-design meeting including the lot owner, and the SARC representatives must occur **prior to design** to ensure that all of the requirements are understood. The lot owner will be responsible for arranging the meetings between the parties. After the meeting, the lot owner will package the information as directed by the SARC representative.*

*The residence should be designed to suit the specific lot dimensions and natural features of the site; prior inspection of the site by the designer is imperative to alleviate future problems. Plans should be accurately and aesthetically drawn by a professional architect or home designer. Landscape plans should be executed by a landscape architect or professional landscaper only. Plans which are drawn by a layman are unacceptable.*

*To ensure the final completion and execution of new construction, or exterior additions, and landscape documents as approved by the SARC, the owner must post a \$1000.00 bond made payable to the Silverwood Plantation Homeowner’s Association. Both the Landscaping and the Architectural Plan(s) must be strictly adhered to once approved by the SARC and must be executed in high quality. Bond will be released at SARC’s approval of completed landscape and building plans compliance.*

#### *Plans and Specifications*

- *will be submitted to the SARC representatives for prior approval:*
- *Floor Plans at ¼” =1’-0”*
- *All Exterior Elevations at ¼” =1’-0”*
- *Typical Wall Sections at 1 ½” =1’-0”*
- *All details necessary to describe the exterior in detail; all elements should be specified thoroughly on the plans.*
- *Exterior materials and colors. Samples must be submitted showing the complete range of colors unless otherwise advised.*
- *Site Plan at 1” =30’ showing required setback lines, required light fixture location, building footprint, driveway location, utility locations, mechanical units and meter locations, and septic system location.*
- *Landscape Plan at 1” =30’ showing existing trees greater than 6” in diameter, existing palmetto beds, walkways, and new plant material (size, quantity, and variety). Grassing and mulching areas should be clearly delineated. Building footprints and required light fixture should be shown.*

Declarant shall prepare architectural guidelines, which may be changed or added to by Declarant at any time and from time to time, for use by an Owner in preparing said plans and specifications. No changes, additions or deviations to or from such plans and specifications as approved, other than to the interior of any building, shall be made without the prior written approval of the Declarant. Further, before beginning any construction, the name of the builder must be submitted to and approved by Declarant as to building experience and ability to build structures of the class and type of those which are to be built on the Property. Declarant shall act with all reasonable promptness upon receipt of such information to approve or disapprove the same. Neither Declarant, nor any person or party to whom Declarant shall assign such function, shall be responsible or liable in any way for the performance of any builder or for any defects in any plans or specifications approved in accordance with the foregoing, nor for any structural defects in any work done according to such plans and specifications.

Declarant may refuse approval of plans, siting or specifications upon any ground, including purely aesthetic considerations, which in its sole discretion shall seem sufficient.

*Required Inspections*

- *SARC representative will be notified **at least 48 hours** (72 hours preferred) in advance of the following construction activities: - Clearing of the site.*
- *Batter boards set for footings.*
- *Pouring of slab*
- *Pouring of driveway*
- *Prior to occupancy*
- *Tree saving areas will be flagged, house and driveway will be staked; SARC representative will field inspect and approve prior to clearing.*
- *All cleared debris will be removed from site during the clearing operation; and burning of debris is prohibited.*
- *A portable, enclosed toilet must be provided during construction. Location shall be approved by SARC representative.*
- *Mud and debris will be kept out of the streets.*
- *Materials and equipment associated with construction will be removed from job site prior to occupancy.*
- *Clearing - Proceed only with SARC's written approval of plan submitted.*

*Job Cleanliness- The construction site will be kept clean on a daily basis. Loose debris will be containerized. Burning of construction trash is prohibited.*

**(d) Building Location.** Each Lot shall have the front building setback lines as shown on the Plat with respect to such Lot. In addition, each Lot shall have side building setback lines on each side boundary of said Lot of fifteen (15) feet for the main residence structure and ten (10) feet for approved detached set back line of thirty (30) feet for the main residence structure and ten (10) feet for approved detached accessory buildings. Declarant reserves the right to align the Plat and this Declaration to change any such setback lines and to control solely and absolutely the precise site and location of any proposed structure or improvement upon all Lots. Such location shall be determined, however, only after reasonable opportunity is afforded the Owner to request a specific site and shall comply with all applicable governmental rules and regulations, including zoning.

**(e) Uniform Lighting.** Contemporaneously with the construction of a residence on a Lot, the Owner thereof shall also install on the Lot an outdoor photocell light fixture and- pole of the type prescribed by Declarant for all Lots. Such light fixture and pole shall be located on the Lot as directed by Declarant and shall be acquired, installed, maintained, repaired and operated at the expense of said Owner. *Lamp Post*

- *Purchase from the SARC, but installed, maintained, repaired and operated at the expense of Lot owner.*
- *20' from side property line on side designated by SARC representative; 5' from front property line, within lot.*
- *Color is black exterior satin paint.*

**(f) Other Building Requirements.** The requirements set forth below are in no way to be construed as limiting the exercise of the Declarant's discretion pursuant to Paragraphs 4b, 4c, and 4d, above.

**(i) Construction Materials.** Each structure shall be constructed only of materials approved in writing by Declarant.

## ***House Requirements***

### ***Dimensional Requirements***

- *Houses to be constructed with a crawl space must have a minimum of 36" between the finished first floor and any existing grade.*
- *Houses to be constructed with a slab on grade must be built up a minimum of 24" between the finished first floor and average existing grade.*
- *Houses with a 2,000 square foot minimum must be constructed with a crawl space.*
- *See Schedule 1 to Exhibit "B" for square footage requirements.*
- *All roofs will have a pitch of no less than 6/12. A pitch of 7/12 or greater is generally recommended for aesthetic purposes.*

### ***Roofs***

- *It is mandatory that asphalt shingles be a textured, three-tab, architectural grade, i.e., Timberline, Elk Prestique series, Georgia Pacific Summit series, or equal.*
- *Asphalt shingles must be of the same color for the entire roof.*
- *Designed baked enamel, ribbed, metal roof panels, or copper.*
- *Wall Finishes/Chimneys*
- *Wood Siding – extreme, roughly sawn siding will **not** be allowed.*
- *Paint or opaque stain; neutral color.*
- *Stucco – smooth textured sand finish.*
- *EIFS System (Dryvit, Sto, etc.) – smooth textured sand finish; neutral color.*
- *Brick – little color variation preferred. Lighter and medium tones preferred.*
- *Concrete block, Masonite and synthetic materials other than stucco will **not** be allowed.*
- *Exposed block or unbrushed concrete foundations will **not** be allowed. Foundations must be either brick veneered, stuccoes, or if poured in concrete, may be lightly brushed and painted.*
- *Hardi (plank or board) or concrete/fiberglass resin will be allowed.*
- *Vinyl siding with no seams, and minimally .042 thickness, formed backing, and can be only on gable ends and dormers. Colors must conform to the house.*

### ***Cornice (i.e., soffit, bird boxes, exterior trim, freeze board, fascia board)***

- *Can be vinyl or aluminum – 0.026 thickness.*
- *Colors must conform to the house.*

### ***Windows***

- *Must be double hung – all glass must be ¾" spaced or greater insulated.*
- *Wood – M&W, Pella, Peachtree, Marvin, Anderson or comparable.*
- *Wood clads in vinyl or wood clad in metal, - Pella, Peachtree, Marvin, Anderson or comparable.*
- *All glass must be set in a frame and mounted within a jamb.*
- *Vinyl with welded corners*
- *Builders grade or single hung windows will **not** be allowed.*

### ***Doors***

- *Hollow core and flush doors will **not** be allowed on the exterior.*
- *Brass plate locksets will **not** be allowed on the exterior.*
- *Solid, polished brass locksets are recommended.*
- *Garage doors are to be raised or recessed panel and will **not** face street in front of house.*
- *Auxiliary single-story buildings with garage doors may face the street.*

### ***Columns and Posts***

- *Columns and posts must be finished in wood, brick or stucco, perm cast, fiberglass, concrete, or vinyl.*

- *Metallic (aluminum or steel especially) columns and piers will **not** be allowed.*

#### Vent Stacks

- *Conceal from view from streets.*
- *Must conform to match roof color.*

#### Swimming Pools

- *Must be in-ground.*
- *Not within 10' of property line*
- *Will **not** be allowed in front of rear line of house.*

#### Quality

- *All finishes, trim and building skin system, must be executed in superior workmanship; cornices, casings, moldings, and decorative features, as well as brickwork, siding, and stucco must be applied as true and straight as possible, forming well defined edges and level planes. Undulating cornices, friezes, and siding, patchy stucco, and poorly laid brick will **not** be tolerated. The SARC will carefully inspect the application of finishes to ensure high quality.*

#### Colors

- *Offensive, loud and distasteful colors (as determined by SARC) will **not** be allowed. Muted, natural tones are preferred.*

#### Framing

- *All framing must be true and straight, executed in good workmanship.*
- *Maximum spacing of joists, studs, and rafters will be 16" o.c.*

#### Plumbing

- *Should be in compliance with local county building codes.*

**(ii) Driveways, Parking Areas.** Shall be constructed only of materials approved in writing by Declarant,

#### Driveway

- *SARC must be notified prior to pouring in for inspection compliance.*
- *Concrete, asphalt, or another approved surface*
- *11' wide, 5" deep unreinforced concrete, 4" reinforced concrete.*
- *Curve driveway to suite natural conditions of site (trees, palmetto beds, topography, etc.); pave swales where driveway crosses. Avoid impairing drainage.*
- *Place driveway no closer than 10' from any property line.*
- *Culverts and headwalls will **not** be allowed.*
- *New or replacement driveways must be cut square where driveway meets street.*

**(iii) Construction Timeline.** The exterior of all structures must be completed within one year after commencement of construction, except where, in the sole discretion of the Declarant such completion within one year is not possible or would result in great hardship to the Owner or builder due to strike, fire, national emergency or natural calamity.

**(iv) Utilities.** All utilities shall be placed underground, and no exterior pole, tower, antenna or other device for the transmission or reception of television signals, radio signals or any other form or electromagnetic radiation, or for any other purpose, shall be erected, placed or maintained on any Lot except as may be constructed by the Declarant or approved in writing by the Declarant. Further, the design, type, location, size, color and intensity of all exterior lighting shall be subject to control by the Declarant and only such exterior lighting as shall have been approved in writing by the Declarant shall be installed or used on any Lot.

**(v) Clotheslines, Garbage Cans, Woodpiles, Dumpsters, Gardens, Play Equipment.** All clotheslines, garbage cans, woodpiles, dumpsters, etc. shall be located or screened so as to be concealed from the view of neighboring Lots

and streets, as approved by Declarant. All rubbish, trash, and garbage shall be regularly removed from the premises and shall not be allowed to accumulate thereon. A vegetable garden may be maintained in the rear yard of a Lot only.

#### Gardens

- *Gardens of a non-ornamental nature (such as vegetable gardens) will **not** be allowed from the rear line of the house forward to the street or within 20' of any property line.*

#### Play Equipment

- *Large semi-permanent play equipment will **not** be allowed from the rear line of the house forward to the street or within 20' from any property line.*
- *Equipment must be of a non-offensive form, material, and color.*

**(vi) Mechanical Equipment.** No heating, air conditioning or other mechanical equipment, and no fuel or water tanks or similar storage receptacles may be exposed to view. Such equipment and receptacles may be installed only within the main or accessory building, buried underground, or otherwise located, or screened so as to be concealed from view of neighboring Lots and streets, as approved by Declarant.

#### Mechanical Units

- *Exterior mechanical units and meters should be located on the rear of a proposed residence; if not, appropriate landscaping must be added to conceal their view from the street.*
- *Equipment – no heating, air conditioning, water pumps, water / fuel tanks, mechanical equipment, or storage receptacles may be exposed to view.*

**(vii) Temporary Structure.** No structure of a temporary character shall be placed upon any Lot at any time, except for shelters used by a building contractor during the course of construction. Such temporary shelters may not, at any time, be used as residences, nor be permitted to remain on the Lot after completion of construction.

**(viii) Accessory Building.** No accessory building shall be placed, upon any part of any Lot except in connection with a residence already constructed or under construction at the time that such outbuilding is placed or erected upon that Lot and with express written approval of Declarant,

#### Auxiliary Buildings

- *Materials and colors will be consistent with the majority of the house.*
- *Setbacks are identical to those of house.*
- *Plans must be approved by SARC.*
- *Prefabricated wood and metal structures are **prohibited**.*
- *One story only.*
- *Auxiliary buildings (i.e., pool house, in-law) must meet local building codes. (See SARC for further information)*

**(ix) Motor Homes, Campers, House/Boat Trailers.** No mobile home or house trailer shall be placed on any Lot at any time for any purpose, and no motor home, camper, tent, shack, or other structure shall be placed on any Lot at any time for use as temporary or permanent occupancy; provided, however, house trailers, temporary buildings and the like shall be permitted for construction purposes during the construction period or as one or more real estate sales offices of Declarant for the sale of property. Motor homes, campers and boat trailers may be kept or parked on a Lot for storage purposes only and only if the same are Operational, are intended for the personal use of the Owner of such lot and are kept or parked in an enclosed garage.

**(x) Cutting Trees, Shrubs, Bushes, Vegetation.** Unless located within ten (10) feet of a main dwelling or accessory building or within ten (10) feet of an approved building site, no trees, shrubs, bushes or other vegetation having a trunk diameter of eight (8) inches or more at two (2) feet above ground level or any dogwood, holly or magnolia tree or bush having a trunk diameter of three (3) inches or more at two (2) feet above ground level may be cut, pruned, mutilated or destroyed at any time without the prior written consent of Declarant; provided, however, that dead or diseased trees, shrubs, bushes or other vegetation shall be cut and removed promptly from any Lot by the Owner thereof.

### Clearing

- *Proceed only with SARC's written approval of any proposed clearing.*
- *Trees to be cleared will be flagged; then SARC representative will field inspect and approve prior to clearing.*
- *All cleared debris will be removed from the site during the clearing operation; burning of debris is prohibited.*
- *Unless located within 10 feet of a main dwelling or auxiliary building or within 10 feet of an approved building site - trees, shrubs, bushes or other vegetation having a trunk diameter of 8 inches or more at 2-foot above ground level may **not** be cut, pruned, mutilated, or destroyed at any time without the prior SARC written approval.*
- *Any (dogwood, holly, or magnolia) tree or bush having a trunk diameter of 3 inches or more at 2-foot above ground level may **not** be cut, pruned, mutilated, or destroyed at any time without the prior SARC written approval.*
- *Dead or diseased trees, shrubs, bushes, or other vegetation shall be removed promptly from any Lot by the owner thereof.*

**(xi)** Any structure used for parking or storage of cars or other motor vehicles shall be enclosed on all sides. No open carports may be placed on any Lot.

**(g) Attachment of Utilities.** No permanent utility connections shall be made to any structure by any utility, public or private, until Declarant has verified general compliance with these covenants and restrictions and with the plans and specifications therefore submitted pursuant to Paragraph © above and has approved said utility connections in writing. Each Lot, when required to be served by a utility, must be served by a water system and other utilities approved by Declarant.

**(h) Signs.** No temporary or permanent signs of any kind shall be erected, placed or maintained on any Lot or the Common Areas except with the written consent of Declarant, or except as may be required by legal proceedings, The approval of signs shall be upon such conditions as may from time to time be determined by Declarant, If such permission is granted, Declarant reserves the right to restrict the size, color, material and content of such signs. Nothing herein shall be construed, however, to prevent Declarant from erecting, placing or maintaining upon any Lot or the Common Areas, during the period of the development and sale of the Lots and/or construction thereon, such signs as Declarant may deem necessary or desirable.

### Signage

- *Temporary signs other than real estate, builder, or legal will **not** be allowed.*
- *Real Estate, builder, or legal – 18" x 24" maximum height.*
- *One sign only per discipline.*
- *Offensive colors or logos will **not** be allowed.*

**(i) Mailboxes and Property Identification Markers.** Declarant reserves the right to approve the location, color, size, design, lettering and all other particulars of mail and newspaper boxes, if any, and of name signs of such boxes, as well as property identification markers.



## Mailbox

- The intent is to have all mail/newspaper boxes consistent for all lots in order to have a neat and dressed appearance. The following box particulars must be maintained by each lot owner:
- **Location:** Current mailbox/newspaper box locations are approved. Newly constructed dwelling lots will have the location to the right-side of the driveway and aligned with existing lot mailbox/newspaper locations of surrounding owner properties.
- **Color:** Mailbox – Black (exterior satin paint)
- **Post** – Sherwin Williams Weather Shield Exterior Satin Cape Cod Gray 28-24 8978-8.75, 8988-2Y9.375, 8991-1Y26.25 – you can use the mailbox paint from the clubhouse for \$5.
- **Numbers** - Black
- **Size of box:** U.S. Postal code 1.5 size box
- **Design:** See exhibit A for design and dimensions of box and supporting post.
- **Lettering:** Numerical numbers will be 3.5" height X 2" wide. The location of numerical numbers will be on both sides and centered, vertically and horizontally. No text letters will be displayed on the exterior of the box or post.
- **Construction:** The mailbox will be of metal material. The post and support structure can either be wood or metal material. Current brick mailbox/newspaper boxes are approved, but if damaged to point of non-use, must revert to wood or metal material design.
- **Height:** The vertical post should be maintained at a 90-degree angle from the ground. The distance from the ground to horizontal post should meet U.S. Postal code specifications.

## Mailbox Particulars

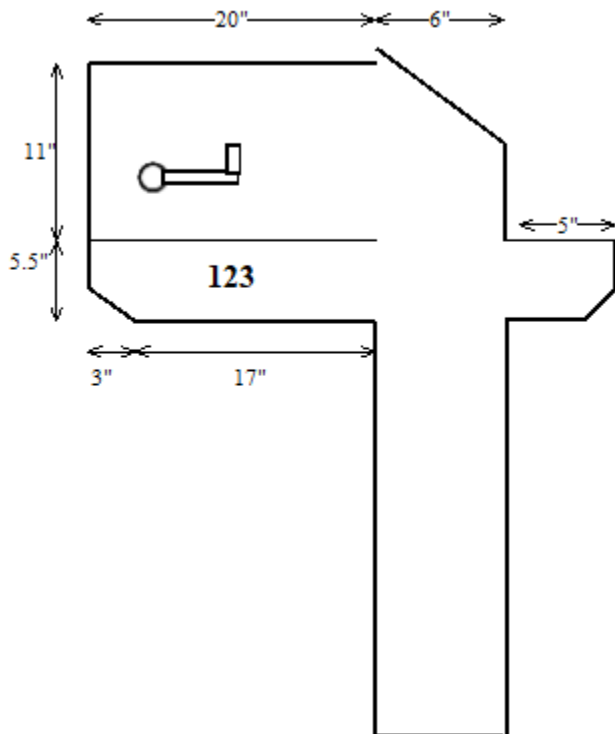

**Exhibit A**

## Property Identification Markers

- The intent is to have all property identification markers/signs consistent for all lots in order to have a neat and dressed appearance.

**(j) Nuisances.** It shall be the responsibility of each Owner to prevent the development of any unclean, unhealthy, unsightly or unkempt condition of buildings or grounds on his Lot or Lots. No Lot shall be used in whole or in part for the storage of any property or thing that will cause such Lot to appear to be in an unclean or untidy condition or that will be obnoxious to the eye; nor shall any substance, thing or material be kept upon any Lot that will emit roué or obnoxious odors, or that will cause any noise or other condition that will or might disturb the peace, quiet, safety, comfort or serenity of the owners of surrounding property. No noxious or offensive activity shall be carried on upon any Lot.

**(k) Animals and Pets.** No animals, livestock or poultry of any kind may be raised, bred, kept or permitted on any Lot, with the exception of dogs, cats or other usual and common household pets in reasonable number, provided that said pets are not kept, bred or maintained for any commercial purpose, are not permitted to roam free, and, in the sole judgment of Declarant, do not endanger the health, make objectionable noise or constitute a nuisance or inconvenience to the Owners of other Lots. Dogs which are household pets shall at all times, whenever they are outside a dwelling, be confined within a pen, fenced yard or on a leash. No structure for the care, housing or confinement of any pets shall be maintained so as to be visible from neighboring property.

Fences

- *Brick, stucco on masonry, treated wood, iron, prefinished metal, brown or green vinyl coated chain link, and vinyl white fences.*
- *6' maximum height.*
- *Style to conform to that of house.*
- *Solid walls and chain link fences will **not** be allowed from rear line of house forward to the street.*
- *Chain link fences will **not** be allowed on corner lots.*
- *If chain link is used, it must be completely concealed from view from any street by means of landscaping.*
- *Decorative fencing will require SARC approval. No prefab panel fencing will be approved.*

**(l) Antennae.** No antenna, satellite dish or other device for the transmission or reception of television signals, radio signals, or any form of electromagnetic radiation shall be erected, used or maintained outdoors on any portion of the Property unless it is not visible from the street.

**(m) Required Maintenance.** All Lots, together with the exterior of all improvements located thereon, shall be maintained in a neat, attractive and safe condition by their respective Owners. Such maintenance shall include, but shall not be limited to, painting, repairing, replacing and caring of roofs, gutters, downspouts, building surfaces, trees, shrubs, grass, walks, parking areas and other exterior improvements. The Association may, after ten (10) days' notice to an Owner, enter upon his Lot for the purpose of mowing, removing, clearing, cutting or pruning underbrush, weeds or other unsightly growth, for removing garbage or trash, or for performing such exterior maintenance as the Association, in the exercise of its discretion, deems necessary or advisable. Any and all direct and indirect costs of such maintenance shall be specially assessed against the Owner of such Lot, which assessment shall be a lien upon the Lot and may be collected as provided in this Declaration. The provisions of this Paragraph shall not be construed, however, as an obligation on the part of the Association to mow, clear, cut or prune any Lot, to provide garbage or trash removal service, or to perform such exterior maintenance.

Maintenance

- *required on all lots to include dwellings, buildings, culverts, ditches, swells, and landscaping.*
- *Culvert/drainage ditches/swells will be maintained by each lot owner(s) to include at a minimum debris cleanout, spraying for vegetation control/removal, and retaining wall maintenance to prevent topsoil erosion. This includes easements that adjoin to the owner lots. Original developer design of culverts/drainage ditches/swells should be maintained by lot owner(s) and alterations / design changes, or obstructions are **not** allowed.*

**5. No Discrimination, no action** shall, at any time, be taken by the Association or its Board of Directors which in any manner would unreasonably discriminate against any Owner or Owners in favor of any other Owner or Owners,

**6. Governmental Regulations.** All governmental building codes, health regulations, zoning restrictions and the like applicable to the Lots and Common Areas shall be observed. In the event of any conflict between any provision of any such governmental code, regulation or restriction and any provision of this Declaration, the more restrictive provision shall apply.

**7. Rules and Regulations.** Rules and Regulations concerning the use of the Common Areas, Lots and improvements located thereon may be made and amended from time to time by the Board of Directors, provided that copies of such Rules and Regulations and amendments thereto shall be furnished by the Association to all Owners upon request. Such Rules and Regulations shall be binding upon the Owners and Occupants until and unless they are cancelled or modified by the Board of Directors. Such Rules and Regulations shall govern activities including but not limited to the following: unsightly and unkempt conditions, water conservation, air, water, and noise pollution, outside storage and traffic control.

# Silverwood Architectural Review Committee (SARC) Approval Request

## Submission Instructions:

- 1) Lot owner should print and fill out form completely and be as specific as possible, include paint swatches when requesting exterior color changes as well as drawings/diagrams/plans.
- 2) Turn SARC form in dropping off at the office, or in the white lockbox located on the Clubhouse porch if not during office hours, or by emailing to [silverwoodplantation@outlook.com](mailto:silverwoodplantation@outlook.com).

Please note that the entire SARC form for the resident part must be filled in and it is approximately a 2-month approval process.

I am requesting the following lot development/architectural work to be approved.

- Install Fencing
- Cut down trees/shrubbery (# \_\_\_\_\_) Please mark with tape prior to Committee Member's visit.
- Change exterior color/design of dwelling/structure (Include drawings/sketches/paintswatches)
- Modify landscaping.
- Other: \_\_\_\_\_

**Describe work above to be performed:** \_\_\_\_\_

\_\_\_\_\_

\_\_\_\_\_

\_\_\_\_\_

**Owner Name (Printed):** \_\_\_\_\_

**Street Address:** \_\_\_\_\_

**Phone Number:** \_\_\_\_\_ **Lot #:** \_\_\_\_\_

**Email Address:** \_\_\_\_\_

**Owner's Signature** \_\_\_\_\_ **Date Submitted:** \_\_\_\_\_

**Target start date:** \_\_\_\_\_ **Target end date:** \_\_\_\_\_

**Date received by SARC member:** \_\_\_\_\_ **Received by:** \_\_\_\_\_

**SARC Member Decision (Check One)**

Approved

Not Approved

**Signature:** \_\_\_\_\_

**Date:** \_\_\_\_\_

**SARC Member Decision (Check One)**

Approved

Not Approved

**Signature:** \_\_\_\_\_

**Date:** \_\_\_\_\_

**Board Member Decision (Check One)**

Approved

Not Approved

**Signature:** \_\_\_\_\_

**Date:** \_\_\_\_\_

**Date returned to lot owner:** \_\_\_\_\_ **Returned by:** \_\_\_\_\_

*Requires 2 SARC Member Signatures and 1 Board Member Signature of Approval BEFORE work can be initiated.*

**\*\*SARC approval does not alleviate any responsibility for compliance with city and county requirements. \*\***

Verified: \_\_\_\_\_

Exhibit B (1-2017)

